

ROOTS

Blowers Compressors Exhausters

ROOTS™ RAM™ Rotary Positive Blowers

Frames 404 thru 624

RAM™ stands for Reliability, Availability and Maintainability. Today, more than ever, Roots is committed to supplying our customers with reliable products manufactured with state-of-the-art CNC machine tools. Production and inventory are being scheduled and controlled to ensure these units will be available when you need them. Design improvements such as repositionable rugged steel mounting feet and die-cast aluminum drive end covers and gear covers help to reduce installation costs and make normal maintenance easier.

BASIC BLOWER DESCRIPTION

RAM™ rotary blowers are heavy-duty units designed with integral-shaft ductile iron impellers having an involute profile. The headplates and rigid, one-piece casing are grey iron, while the drive end cover and gear cover are aluminum. Carburized and ground alloy steel spur timing gears are taper mounted on the shafts, secured with a locknut. Cylindrical roller bearings are used on all units.

Piston rings reduce air leakage through the shaft openings in the headplates, and lip-type oil seals prevent lubricant from entering the air chamber. A hydrodynamic seal on the drive shaft prevents shaft seal oil leaks.

RAM rotary blowers incorporate thrust control, with splash oil lubrication at both ends of the blower.

All frame sizes are designed with detachable rugged steel mounting feet which permit in-field adaptability to either vertical or horizontal installation requirements.

The top shaft is extended for drive on side outlet blowers, and either shaft can be extended for drive on top or bottom outlet blowers.

WARRANTY PERIOD

Twenty-Four (24) months from date of original unit start-up or 30 months from date of original shipment, whichever occurs first.



DESIGN AND CONSTRUCTION FEATURES

1. Horizontal and vertical configurations available
2. Improved volumetric efficiency and reduced operating temperatures
3. Alloy steel timing gears
4. Cylindrical roller bearings
5. Piston ring air seals
6. Lip-type, hydrodynamic oil seals,
7. Splash oil lubrication

OPERATING PRINCIPLE

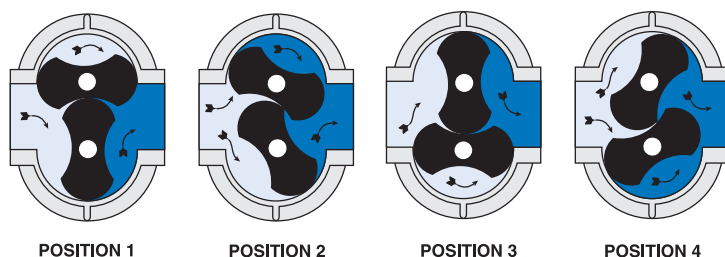

Two figure-eight lobe impellers mounted on parallel shafts rotate in opposite directions. As each impeller passes the blower inlet, it traps a definite volume of air and carries it around the case to the blower outlet, where the air is discharged. With constant speed operation the displaced volume is essentially the same regardless of pressure, temperature or barometric pressure. Timing gears control the relative position of the impellers to each other and maintain small but definite clearances. This allows operation without lubrication being required inside the air casing.



PERFORMANCE TABLE

| Frame Size | Speed RPM | 4 PSI | | 6 PSI | | 8 PSI | | 10 PSI | | 12 PSI | | 15 PSI | | 18 PSI | | MAX VACUUM | | |
|------------|-----------|-------|------|-------|-------|-------|-------|--------|-------|--------|-------|--------|-------|--------|------|------------|-------|------|
| | | CFM | BHP | CFM | BHP | CFM | BHP | CFM | BHP | CFM | BHP | CFM | BHP | CFM | BHP | "HG | CFM | BHP |
| 404 | 1750 | 148 | 3.6 | 139 | 5.3 | 130 | 6.9 | 123 | 8.6 | 116 | 10.3 | | | | | 14.0 | 114 | 5.8 |
| | 2950 | 280 | 6.8 | 271 | 9.5 | 262 | 12.3 | 255 | 15.1 | 248 | 17.9 | 239 | 22 | | 15.0 | 240 | 10.8 | |
| | 4000 | 396 | 10.4 | 386 | 14.1 | 378 | 17.8 | 370 | 21.5 | 364 | 25.2 | 355 | 30.7 | 347 | 36.2 | 16.0 | 350 | 15.8 |
| 406 | 1750 | 225 | 5.4 | 210 | 7.9 | 198 | 10.5 | 187 | 13 | 177 | 15.5 | | | | 14.0 | 173 | 8.8 | |
| | 2950 | 426 | 10.0 | 411 | 14.2 | 398 | 18.4 | 387 | 22.6 | 377 | 26.8 | 363 | 33.2 | | 15.0 | 365 | 16.2 | |
| | 4000 | 601 | 15.1 | 586 | 20.7 | 574 | 26.3 | 562 | 31.9 | 552 | 37.5 | 539 | 45.9 | 526 | 54.3 | 16.0 | 531 | 23.7 |
| 409 | 1750 | 338 | 8.0 | 315 | 11.8 | 296 | 15.6 | 279 | 19.4 | 264 | 23.2 | | | | 14.0 | 259 | 13.2 | |
| | 2950 | 638 | 14.7 | 615 | 21 | 596 | 27.3 | 579 | 33.6 | 564 | 39.9 | 544 | 49.3 | | 15.0 | 546 | 24.2 | |
| | 4000 | 900 | 21.9 | 878 | 30.3 | 859 | 38.7 | 842 | 47 | 827 | 55.4 | 806 | 68 | 788 | 80.5 | 16.0 | 796 | 35.2 |
| 412 | 1750 | 450 | 10.6 | 420 | 15.7 | 394 | 20.7 | 372 | 25.8 | 352 | 30.8 | | | | 14.0 | 344 | 17.6 | |
| | 2950 | 849 | 19.4 | 819 | 27.8 | 794 | 36.2 | 772 | 44.6 | 752 | 52.9 | 724 | 65.5 | | 15.0 | 728 | 32.1 | |
| | 4000 | 1199 | 28.8 | 1169 | 39.9 | 1144 | 51.1 | 1121 | 62.2 | 1101 | 73.4 | 1074 | 90.1 | | 16.0 | 1060 | 46.6 | |
| 418 | 1750 | 675 | 15.9 | 630 | 23.5 | 592 | 31.1 | 559 | 38.7 | | | | | | 14.0 | 517 | 26.4 | |
| | 2950 | 1275 | 28.9 | 1230 | 41.5 | 1192 | 54.1 | 1159 | 66.7 | | | | | | 15.0 | 1092 | 48.1 | |
| | 4000 | 1800 | 42.8 | 1755 | 59.5 | 1717 | 76.3 | 1684 | 93.0 | | | | | | 16.0 | 1591 | 69.8 | |
| 616 | 1170 | 671 | 16.6 | 614 | 24.6 | 566 | 32.6 | 524 | 40.6 | 486 | 48.6 | | | | 13.0 | 501 | 25.7 | |
| | 1750 | 1128 | 25.6 | 1072 | 37.5 | 1024 | 49.4 | 982 | 61.3 | 943 | 73.2 | | | | 14.0 | 929 | 41.7 | |
| | 3000 | 2115 | 49.0 | 2058 | 68.8 | 2010 | 88.6 | 1968 | 108.4 | 1930 | 128.2 | 1878 | 157.9 | | 16.0 | 1851 | 81.8 | |
| 624 | 1170 | 1006 | 25.1 | 921 | 37.1 | 849 | 49.1 | 786 | 61.1 | | | | | | 13.0 | 751 | 38.8 | |
| | 1750 | 1693 | 39.3 | 1608 | 57.2 | 1536 | 75.0 | 1473 | 92.8 | | | | | | 14.0 | 1394 | 63.0 | |
| | 3000 | 3173 | 77.6 | 3088 | 107.3 | 3016 | 137.1 | 2953 | 166.8 | | | | | | 16.0 | 2777 | 124.8 | |

Notes: 1. Pressure ratings based on inlet air at standard pressure of 14.7 psia, standard temperature of 68° F, and specific gravity of 1.0.
 2. Vacuum ratings based on inlet air at standard temperature of 68°F, discharge pressure of 30" Hg and specific gravity of 1.0.

OUTLINE DRAWING & DIMENSIONAL TABLE

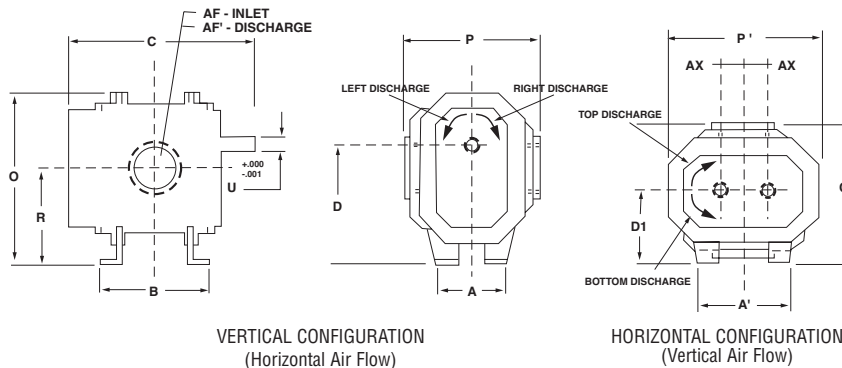

| Frame Size | A | A' | B | C | Drive Shaft Location | | O | O' | P | P' | R | U | Keyway | AF Inlet Diameter | AF' Discharge Diameter | AX | Approx. NetWt (lbs) |
|------------|-------|-------|-------|-------|----------------------|------|-------|-------|-------|-------|-------|-------|------------|-------------------|------------------------|------|---------------------|
| | | | | | D | D1 | | | | | | | | | | | |
| 404 | 8.00 | 11.00 | 8.75 | 18.50 | 11.25 | 7.50 | 16.63 | 13.50 | 12.00 | 15.25 | 9.00 | 1.500 | .375 x.188 | 3.0 NPT | 3.0 NPT | 2.25 | 200 |
| 406 | 8.00 | 11.00 | 10.75 | 20.50 | 11.25 | 7.50 | 16.63 | 13.50 | 12.00 | 15.25 | 9.00 | 1.500 | .375 x.188 | 4.0 NPT | 4.0 NPT | 2.25 | 230 |
| 409 | 8.00 | 11.00 | 13.75 | 23.50 | 11.25 | 7.50 | 16.63 | 13.00 | 11.00 | 15.25 | 9.00 | 1.500 | .375 x.188 | 4.0 NPT | 4.0 NPT | 2.25 | 270 |
| 412 | 8.00 | 11.00 | 16.75 | 26.50 | 11.25 | 7.50 | 16.63 | 13.00 | 11.00 | 15.25 | 9.00 | 1.500 | .375 x.188 | 6.0 FLG | 6.0 FLG | 2.25 | 330 |
| 418 | 8.00 | 11.00 | 22.75 | 32.50 | 11.25 | 7.50 | 16.63 | 13.00 | 11.00 | 15.25 | 9.00 | 1.500 | .375 x.188 | 8.0 FLG | 8.0 FLG | 2.25 | 410 |
| 616 | 10.00 | 16.00 | 20.75 | 32.44 | 15.00 | 9.00 | 22.00 | 16.25 | 14.50 | 20.00 | 12.00 | 2.000 | .500 x.250 | 8.0 FLG | 8.0 FLG | 3.00 | 650 |
| 624 | 10.00 | 16.00 | 28.75 | 40.44 | 15.00 | 9.00 | 22.00 | 16.25 | 14.50 | 20.00 | 12.00 | 2.000 | .500 x.250 | 10.0 FLG | 10.0 FLG | 3.00 | 775 |

Notes: 1. All dimensions are in inches. 2. Do not use for construction.



| | | |
|--|--|---|
| Headquarters 16240 Port Northwest Drive Houston, TX 77041 Toll Free (US): 1-877-363-7668 Ph: 832-590-2305 Toll Free (US) Fax: 1-877-357-7238 Fx: 832-590-2326 | Connersville Operation 900 West Mount Street Connersville, IN 47331 Ph: 765-827-9200 Fx: 765-827-9266 | Huddersfield Operation PO Box B7 Off St. Andrews Rd Turnbridge, Huddersfield England HD1 6RB Ph: +44 (0) 1484 42 22 22 Fx: +44 (0) 1484 42 34 29 |
|--|--|---|

S-28F98
June 2006

website: www.rootsblower.com • US email: roots@dresser.com • UK email: dmd_roots@dresser.co.uk

©2006 Dresser, Inc. all rights reserved. • Printed in the U.S.A. • All information subject to change without notice. • EasyAir, ROOTS-FLO and Universal RAI are registered trademarks of Dresser, Inc. • ROOTS, TRI-NADO, The Original ROOTS Blower, Universal RAI-J, Universal RAI-G, RAM, WHISPAIR, XLP Prime and XLP are trademarks of Dresser, Inc.